

# Loss-of-Function *ENPP1* Mutations Cause Both Generalized Arterial Calcification of Infancy and Autosomal-Recessive Hypophosphatemic Rickets

Bettina Lorenz-Depiereux,<sup>1</sup> Dirk Schnabel,<sup>2</sup> Dov Tiosano,<sup>3,4</sup> Gabriele Häusler,<sup>5</sup> and Tim M. Strom<sup>1,6,\*</sup>

The analysis of rare genetic disorders affecting phosphate homeostasis led to the identification of several proteins that are essential for the renal regulation of phosphate homeostasis; for example, fibroblast growth factor 23 (FGF23), which inhibits renal phosphate reabsorption and 1,25-dihydroxyvitamin D synthesis. Here, we report presumable loss-of-function mutations in the *ENPP1* gene (ectonucleotide pyrophosphatase/phosphodiesterase) in members of four families affected with hypophosphatemic rickets. We provide evidence for the conclusion that *ENPP1* is the fourth gene—in addition to *PHEX*, *FGF23*, and *DMP1*—that, if mutated, causes hypophosphatemic rickets resulting from elevated FGF23 levels. Surprisingly, *ENPP1* loss-of-function mutations have previously been described in generalized arterial calcification of infancy, suggesting an as yet elusive mechanism that balances arterial calcification with bone mineralization.

Hypophosphatemia is a heterogeneous disease with an incidence of 1 in 20,000 newborns. The majority of patients are affected by the X-linked form of hypophosphatemia (XLH [MIM 307800]) caused by *PHEX* mutations.<sup>1</sup> Singular cases have been reported with mutations in *FGF23* (ADHR [MIM 193100])<sup>2</sup> and *DMP1* (MIM 241520),<sup>3</sup> which show autosomal-dominant and -recessive inheritance, respectively. Mutations in all three genes lead to increased FGF23 plasma levels. Functional analysis indicated that FGF23, which is expressed by osteocytes, is a key regulator of phosphate reabsorption and of 1,25-dihydroxyvitamin D synthesis in the proximal renal tubules.<sup>4,5</sup> Cases of hypophosphatemia remain, including familial and consanguineous ones, which do not show mutations in any of these three genes, suggesting further genetic heterogeneity.

Here, we identified three different homozygous, presumable loss-of-function mutations in *ENPP1* that were present in five individuals with hypophosphatemic rickets and were not present in 359 controls. *ENPP1* is a major generator of extracellular pyrophosphate (PPi), which inhibits hydroxyapatite crystal deposition and growth.<sup>6</sup> Furthermore, overexpression of *ENPP1* has been involved in type 2 diabetes mellitus.<sup>7</sup> Surprisingly, inactivating mutations in this gene have previously been described to cause generalized arterial calcification of infancy (GACI [MIM 208000]), a severe autosomal-recessive disorder with a hypermineralizing phenotype.<sup>8</sup> That both GACI and hypophosphatemic rickets are caused by loss-of-function mutations is most strongly supported by our observation of a single family, in which the father has hypophosphatemic rickets whereas his son is affected by severe GACI plus

hypophosphatemia, although both carry the same homozygous *ENPP1* mutation.

We investigated a cohort of 60 index cases who were referred to us because of hypophosphatemia and were proven negative for *PHEX*, *FGF23*, and *DMP1* mutations. We first performed genome-wide linkage analysis by using SNP array genotyping in two familial cases (families 1 and 2). Assuming that the disease alleles could be identical by descent in each family, we analyzed the data by homozygosity mapping and identified a 4.1 Mb candidate region on chromosome 6q23 between SNPs rs9388766 and rs6569926 containing approximately 35 genes, among them the *ENPP1* gene. We considered *ENPP1* a candidate because hypophosphatemia has been reported to occur in some patients with GACI and to alleviate arterial calcification in these patients.<sup>9</sup> We therefore searched for *ENPP1* mutations by direct sequencing in all 60 index cases and identified three different homozygous, presumable loss-of-function mutations in *ENPP1* in the two families used for homozygosity mapping and in two additional families. Each of the unaffected parents, when available, were heterozygous for the respective mutation (Figure 1 and Table 1). The two affected brothers in family 1 carried a homozygous deletion of the last two exons of *ENPP1* (exons 24 and 25, c.2445-798\_2778\*867del), truncating the C-terminal part of the nuclease-like domain of the protein. Sequencing of a junction fragment revealed a 5615 bp deletion at chromosome 6 from position 132,248,597 to 132,254,212 (according to the UCSC Genome Assembly build hg18). The breakpoints lie within single-copy sequences in intron 23 and the 3' UTR. The affected individual in family 3 had a homozygous 1 bp

<sup>1</sup>Institute of Human Genetics, Helmholtz Zentrum München, German Research Center for Environmental Health, 85764 Neuherberg, Germany; <sup>2</sup>Department of Pediatric Endocrinology, Charité-Universitätsmedizin Berlin, 13353 Berlin, Germany; <sup>3</sup>Pediatric Endocrinology, Meyer Children's Hospital, Rambam Medical Center, 31096 Haifa, Israel; <sup>4</sup>Faculty of Medicine, Technion-Israel Institute of Technology, 31096 Haifa, Israel; <sup>5</sup>Department of Pediatrics, Medizinische Universität Wien, 1090 Vienna, Austria; <sup>6</sup>Institute of Human Genetics, Klinikum rechts der Isar, Technische Universität München, 81675 Munich, Germany

\*Correspondence: [timstrom@helmholtz-muenchen.de](mailto:timstrom@helmholtz-muenchen.de)

DOI 10.1016/j.ajhg.2010.01.006. ©2010 by The American Society of Human Genetics. All rights reserved.

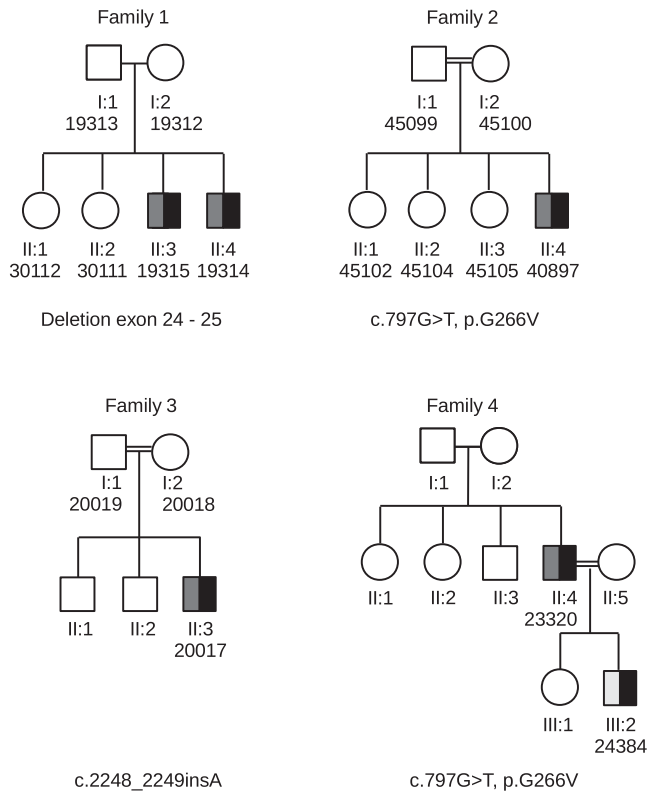

**Figure 1. *ENPP1* Mutations in Four Families with Autosomal-Recessive Hypophosphatemia**

The different clinical phenotypes are indicated by half filled boxes; light gray:GACI, dark gray:rickets and black:hypophosphatemia. DNA was available from all patients labeled with a DNA identifier. Patient 23320 and his son 24384 in family 4 carry the same homozygous *ENPP1* mutation, but with different clinical outcome.

insertion in exon 22 (c.2248\_2249insA), leading to a premature translation termination codon after five amino acids (p.Ser750LysfsX6), disrupting most of the nuclease-like domain. The probands in families 2 and 4 carried a nonsynonymous sequence variation at the second nucleotide of exon 8, which substituted a glycine for a valine (c.797G>T [p.Gly266Val]). This amino acid residue is located within the catalytic domain of the enzyme and is highly conserved within vertebrate species. We also found three heterozygous noncoding variants and one coding variant that were not present in 718 control chromosomes (Table 1); three of the variants were found in an affected individual of African origin (11965). To our knowledge, all identified mutations have not been described in GACI before (Figure 2).<sup>9</sup>

Hypophosphatemia is assumed to be mediated by elevated FGF23 plasma levels, which affects expression and internalization of the renal sodium-phosphate cotransporters SLC34A1 and SLC34A3 and inhibits 1- $\alpha$ -hydroxylation of 25-hydroxyvitamin D. This is supported by the observation that FGF23 plasma levels are elevated or inappropriately high in many patients with hypophosphatemia due to mutations in *PHEX*, *FGF23* or *DMP1*. To

**Table 1. *ENPP1* Sequence Variations**

Sequence Variation	Patients	Position	Minor Allele in Controls <sup>a</sup>		
			European	Turkish	Arabic
<b>Homozygous Mutations</b>					
c.2445-798_2778*867del	19315, 19314	exon 24–25	-	-	-
c.2248_2249insA (p.S750KfsX6)	20017	exon 22	0	0	0
c.797G>T (p.G266V)	23320, 24384, 40897	exon 8	0	0	0
<b>Heterozygous Variations</b>					
c.314-64G>A	11965	intron 2	0	0	0
c.556+3C>A	25552	intron 4	0	0	0
c.1091+130G>A	11965	intron 10	0	0	0
c.1329T>C (p.D443D)	11965	exon 13	0	0	0
c.1-10C>T	22061, 12364	5' UTR	9	2	2
c.1-35G>T	30691, 31756	5' UTR	23	3	15

Mutation numbering is based on GenBank entry BC059375 for *ENPP1*, +1 corresponding to the A of the translation-initiation codon. This numbering is compatible with the mutation nomenclature in previous *ENPP1* mutation reports.

<sup>a</sup> 184 European, 83 Turkish, and 92 Israeli-Arabic individuals were used as controls.

investigate whether hypophosphatemia due to *ENPP1* mutations is also mediated by FGF23, we measured FGF23 plasma levels in all studied individuals with two different ELISAs, one of them detecting both C-terminal and intact FGF23 and the other detecting only intact FGF23. Whereas the values of the C-terminal/intact assay were in the normal range, the values of the intact assay were clearly elevated in one individual and were slightly elevated or in the upper normal range in the remaining five individuals (Table 2). These findings are similar to those observed in XLH. Although only some of the affected individuals show FGF23 levels above the normal range, the levels are inappropriately high in the context of low phosphate serum levels. The phosphaturia observed in patients with *ENPP1* mutations could thus also be FGF23 dependent. Furthermore, given that FGF23 also inhibits 1- $\alpha$ -hydroxylation, elevated FGF23 concentrations could provide an explanation for the inappropriately low 1,25-dihydroxyvitamin D levels observed in all affected individuals.

Surprisingly, the identification of two *ENPP1* truncating mutations and the recessive phenotype suggest loss of function as the mechanism leading to hypophosphatemic rickets, the same mutational mechanism that is supposed to be causative in patients with GACI. We therefore thoroughly reexamined the case history and the current disease status of the five individuals with hypophosphatemic

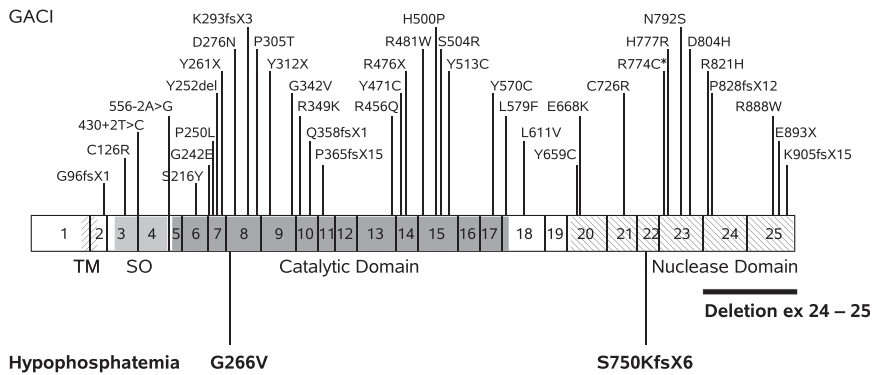

**Figure 2. Position of *ENPP1* Mutations Causing Hypophosphatemic Rickets or GACI**  
 Distribution of *ENPP1* mutations. *ENPP1* exons are represented as boxes 1-25. Mutations published previously in patients with GACI<sup>9</sup> are indicated above the gene; mutations detected in this study are drawn below the gene. Functional domains are indicated by gray and hatched areas. TM:transmembrane domain, SO: somatomedin B-like domain. Asterisk: rs28933977.

rickets. All individuals were diagnosed with rickets in their childhood and had the characteristic laboratory findings; i.e., decreased serum phosphate levels, decreased renal phosphate reabsorption, and elevated serum alkaline phosphatase, but normal serum calcium, parathyroid hormone, and 1,25-dihydroxyvitamin D levels (Table 2 and Table 3). Some of the 1,25-dihydroxyvitamin D levels are in the upper normal range, but they are far below values expected in physiological hypophosphatemia. Furthermore, the severity of the hypophosphatemic phenotype is documented by the need to perform surgical

corrections of bone deformities in three of the affected individuals. To assess possible arterial calcifications, we performed ultrasound examinations of the large blood vessels after the identification of the *ENPP1* mutations. The examinations showed normal carotid and renal arteries and a normal thoracic and abdominal aorta. Nephrocalcinosis found in patient 20017 is not typical for GACI, but it does frequently develop in hypophosphatemia. However, patient 23320 developed an aortic root dissection at the age of 28 yrs, and echocardiography after identification of the *ENPP1* mutations revealed mild

**Table 2. Chemical and Clinical Data**

	Family 1		Family 2	Family 3	Family 4		Ref. Range
	19315 <sup>a</sup>	19314 <sup>a</sup>	40897 <sup>b</sup>	20017 <sup>b</sup>	23320 <sup>a</sup>	24384 <sup>a</sup>	
FGF23 intact (pg/ml) <sup>c</sup>	50, 51	49, 55	116, 122	41, 48	71, 56	81, 56, 54	10–50
FGF23 C-t RU/ml <sup>d</sup>	82	101	23	36	33	63	< 120–150
Ca (mmol/l)	2.48	2.44	2.28	2.5	2.24	2.29	2.15–2.64
P (mmol/l)	0.72 (0.97–1.68)	0.74 (0.97–1.68)	0.35 (0.81–1.45)	0.49 (0.81–1.45)	0.84 (1.2–1.8)	0.72 (1.05–1.8)	
AP (U/l)	649 (130–550)	656 (130–550)	337 (< 130)	66 (30–115)	818 (< 380)	302 (< 380)	
PTH (ng/l)	35.6	24.0	59	35	62	28.1	12–65
25OHD (nmol/l)	157.7	153.5	26.7	70.2	56.7	45.7	30–120
1,25(OH) <sub>2</sub> D (pmol/l)	168.0	235.2	163.2	199.2	118.3	129.8	86–230
U Ca/Cr (mmol/mmol)			0.11	0.28	0.51	0.20	< 0.59
TRP (%)	82	83	69	97.1	79		83–95
TmP/GFR (mmol/l)	0.68	0.68	0.24	0.65	0.35	0.78	0.8–1.4
Ultrasound of the large blood vessels	normal	normal	normal	normal	normal	calcifications	
Echocardiography	thickening of aortic valves	normal	normal	mild pulmonary stenosis	aortic root dissection		

FGF23 levels are current measurements and have been determined in a single laboratory after treatment withdrawal of at least 14 days; for some individuals, the results of two or more measurements are provided. All other laboratory investigations have been performed by the referring hospitals as indicated. Abbreviations are as follows: Ref. range, reference range; Ca, calcium; P, phosphate; AP, alkaline phosphatase; PTH, parathyroid hormone; 25OHD, 25-hydroxyvitamin D; 1,25(OH)<sub>2</sub>D, 1,25-dihydroxyvitamin D; U Ca/Cr, urine calcium:creatinine ratio; TRP, tubular reabsorption of phosphate; TmP/GFR, maximum tubular phosphate reabsorption to glomerular filtration rate. Informed consent was obtained from all study participants. The study was approved by the institutional review board of the Medical Department of the Technische Universität München.

<sup>a</sup> Values measured at time of diagnosis before therapy.

<sup>b</sup> Current measurements after at least 14 days of treatment withdrawal. Reference values are given in the last column or in parenthesis next to the single values for age- and sex-dependent values.

<sup>c</sup> FGF23 intact: assay measuring intact FGF23. Reference ranges for the FGF23 assays are taken from Yamazaki et al.<sup>14</sup> and Imel et al.<sup>15</sup> Reference values determined in our own laboratory for the full-length assay have a mean of 34 and a standard deviation of 12.5 (n = 28).

<sup>d</sup> FGF23 C-t: assay measuring C-terminal and intact FGF23. Reference ranges for the FGF23 assays are taken from Yamazaki et al.<sup>14</sup> and Imel et al.<sup>15</sup>

**Table 3. Summary of Case Histories**

	<b>Family 1</b>		<b>Family 2</b>	<b>Family 3</b>	<b>Family 4</b>	
	<b>19315</b>	<b>19314</b>	<b>40897</b>	<b>20017</b>	<b>23320</b>	<b>24384</b>
Origin	Turkish	Turkish	Turkish	Israeli Arabic	Turkish	Turkish
Consanguinity of parents	denied	denied	first-degree cousins	first-degree cousins	denied	first-degree cousins
Siblings	two healthy sisters	two healthy sisters	three healthy sisters	two healthy brothers	three healthy siblings	one healthy sister
Age at diagnosis (yrs)	8	2.5	16.8	6	5.5	first week of life <sup>a</sup>
Present age (yrs)	17	11	20	21	35	10
Present height (cm) (SD)	167.3 (−1.2)	130 (−2.3)	159.6 (−2.5)	148 (−5)	151.6 (−3.6)	112.5 (−4)
Sitting height (cm) (SD)	97.3 (+1.5)	73.2 (−0.72)	93.2 (+2.3)			
Leg length (cm) (SD)	70 (−3.2)	56.8 (−2.5)				
Rickets	yes	yes	yes	yes	yes	no
Bone deformities	genua vara since 2 years of age	genua vara since early walking age	genua valga since early walking age		coxa valga	
Osteotomy (no. of times)	2	0	5	0	1	0
Time of treatment	since diagnosis	since diagnosis	since diagnosis	since diagnosis	since diagnosis until 20 yrs of age	since the first week of life
Phosphate supplementation	40 mg/kg/d	40 mg/kg/d	40 mg/kg/d	60 mg/kg/d	40 mg/kg/d	
1,25(OH) <sub>2</sub> D supplementation	15 ng/kg/d	15 ng/kg/d	15 ng/kg/d		15 ng/kg/d	
1OHD supplementation				10 ng/kg/d		
Renal ultrasound	no interstitial calcifications	no interstitial calcifications	no interstitial calcifications	increased pyramidal echogenicity, medullary nephrocalcinosis	slightly increased pyramidal echogenicity	
Miscellaneous	growth-hormone therapy during age 12–16 yrs				development of an aortic root dissection at the age of 28 yrs, which was supplied with composite graft; since this time, patient has received heparin and β-adrenergic blockers	

<sup>a</sup> Echocardiography within the first week of life revealed increased echogenicity and thickening of the wall of both the abdominal aorta up to the iliac bifurcation and the kidney arteries. X-ray examination of the shoulder and hip joints showed periarticular calcifications. At the age of 2 wks, bisphosphonate (etidronate 15 mg/kg/d) and low-dose nifedipin treatment was initiated. Under this treatment, cardiac function was stable and blood pressure was within the normal range. At the age of 12 mo, the patient developed hypophosphatemia and decreased renal phosphate reabsorption. At the age of 4 yrs, he developed necrosis of the hip joints and labyrinthine deafness, most likely because of calcification of the supplying arteries. This patient was described previously.<sup>8</sup> The mutation reported in this paper (c.2320C>T [p.Arg774Cys]) has since been shown to be a polymorphism (rs28933977) with a minor allele frequency of 5%. Standard deviation scores for height are given in parenthesis. 1OHD, 1-hydroxyvitamin D; 1,25(OH)<sub>2</sub>D, 1,25-dihydroxyvitamin D.

pulmonary stenosis in patient 20017 and thickening of the aortic valves with incomplete opening in patient 19315. There was no evidence to indicate that the cardiac alterations occurred as a result of arterial calcifications. However, arterial alterations without calcifications have been described in GACI.<sup>10</sup> Thus, at diagnosis and during several years of treatment, the affected individuals showed clinical and biochemical parameters that were not distinguishable from those observed in XLH and ADHR. Current investigations, however, suggest that these patients are susceptible to anomalies of the cardiac valves.

In summary, mutations described in this study are predicted to abolish ENPP1 activity and are associated with inappropriately high FGF23 plasma levels. *ENPP1* is therefore the fourth gene that, if mutated, causes hypophosphatemic rickets due to elevated FGF23 levels.

Two explanations, which can act alone or in combination, may explain why loss-of-function mutations of *ENPP1* are associated with hypophosphatemic rickets in some patients and with GACI in others. The first explanation is that these phenotypes are expressed to a variable degree depending on the genetic and environmental

**Table 4. SLC34A3 and SLC34A1 Sequence Variations**

Sequence Variation	Patients	Position	rsSNP	MAF	Comment
<b>SLC34A1</b>					
c.259+4G>A	19315	intron 3	-	NA	splice score unchanged
c.774T>C (p.H258H)	40897, 20017, 23320, 24384	exon 7	rs5030873	NA	synonymous
<b>SLC34A3</b>					
c.757T>C (p.L253L)	19315, 40897	exon 8	rs28407527	0.4–0.435 <sup>a</sup>	synonymous
c.942G>C (p.A314A)	23320, 24384	exon 10	rs34664302	0.009 <sup>a</sup>	synonymous
c.1009G>A (p.G337S)	23320, 24384	exon 10	rs35699762	0.01–0.37 <sup>a</sup>	non-synonymous

Abbreviations are as follows: MAF, minor allele frequency; NA, not available.  
<sup>a</sup> Lorenz-Depiereux et al.<sup>16</sup>

background of the affected individuals. This is the most likely possibility, because there have been described patients with a mild GACI phenotype who have both arterial calcifications and concomitant hypophosphatemia and hyperphosphaturia.<sup>9</sup> In addition, we observed in this study two members of the same family, carrying the same homozygous *ENPP1* mutation, one having hypophosphatemic rickets without arterial calcifications and the other being affected by GACI with hypophosphatemia. The identification of modifiers is unlikely in such a small number of patients unless their effect is large. We excluded any obvious sequence mutations in the renal sodium-phosphate cotransporters *SLC34A1* (MIM 182309) and *SLC34A3* (MIM 241530) (Table 4). We detected two unknown variations in *SLC34A1* and three known variations in *SLC34A3*. A modifying function of the rare SNPs rs34664302 and rs35699762 seems to be excluded because they were present in the two individuals having either hypophosphatemic rickets or GACI.

The second explanation is that the functional differences are related to the different mutant alleles. Although there is no evidence for different isoforms of the *ENPP1* protein and in both diseases the mutations are spread across the entire gene (Figure 2), there remains a possibility that the effect of the mutations on the protein level is different for the two phenotypes.

A gain-of-function mechanism is unlikely, however, not only because of the mutation type but also because of current functional knowledge. There is evidence that PPI levels are regulated by opposing actions of *ENPP1*, which generates PPI, and tissue-nonspecific alkaline phosphatase (TNAP), which degrades PPI into inorganic phosphate.<sup>6,11</sup> Because PPI is a potent inhibitor of hydroxyapatite crystal deposition and osteoblast differentiation, regulation of *ENPP1* expression levels must be tightly controlled. Low PPI levels result in pathological calcifications, as in patients with GACI<sup>8</sup> and in *ttw* (tiptoe walking) mice,<sup>12</sup> whereas excess PPI levels leads to calcium pyrophosphate dihydrate (CPPD) crystal formation, as in idiopathic chondrocalcinosis or CPPD deposition disease.<sup>13</sup> This phenotype is different from hypophosphatemic rickets, as is the pheno-

type in a recently described mouse model ubiquitously overexpressing *ENPP1* (Jacobi et al., 2009, *J. Bone Miner. Res.*, abstract). Although the functional differences remain elusive, the identification of *ENPP1* mutations may have important consequences for the affected individuals, given that the current treatment of hypophosphatemia with phosphorus and 1,25-dihydroxyvitamin D supplementation may trigger arterial calcifications.

#### Acknowledgments

We thank the families for participation in this study. We also thank S. Lösecke for technical assistance and Thomas Meitinger for discussions and comments. This work was supported by a grant of the Deutsche Forschungsgemeinschaft. B.L.-D., D.S., D.T., and G.H. declare that they do not have a financial interest related to this work. T.M.S. receives royalties from licensing FGF23 to Kirin Pharmaceuticals.

Received: October 23, 2009

Revised: January 4, 2010

Accepted: January 8, 2010

Published online: February 4, 2010

#### Web Resources

The URLs for data presented herein are as follows:

dbSNP, <http://www.ncbi.nlm.nih.gov/SNP>

Online Mendelian Inheritance in Man (OMIM), <http://www.ncbi.nlm.nih.gov/Omim/>

University of California-Santa Cruz (UCSC) Human Genome Browser, <http://genome.ucsc.edu>

#### References

1. The HYP Consortium. (1995). A gene (*PEX*) with homologies to endopeptidases is mutated in patients with X-linked hypophosphatemic rickets. *Nat. Genet.* 11, 130–136.
2. The ADHR Consortium. (2000). Autosomal dominant hypophosphatemic rickets is associated with mutations in *FGF23*. *Nat. Genet.* 26, 345–348.
3. Lorenz-Depiereux, B., Bastepe, M., Benet-Pages, A., Amyere, M., Wagenstaller, J., Muller-Barth, U., Badenhop, K., Kaiser,

- S.M., Rittmaster, R.S., Shlossberg, A.H., et al. (2006). DMP1 mutations in autosomal recessive hypophosphatemia implicate a bone matrix protein in the regulation of phosphate homeostasis. *Nat. Genet.* 38, 1248–1250.
4. Quarles, L.D. (2008). Endocrine functions of bone in mineral metabolism regulation. *J. Clin. Invest.* 118, 3820–3828.
  5. Strom, T.M., and Juppner, H. (2008). PHEX, FGF23, DMP1 and beyond. *Curr. Opin. Nephrol. Hypertens.* 17, 357–362.
  6. Goding, J.W., Grobber, B., and Slegers, H. (2003). Physiological and pathophysiological functions of the ecto-nucleotide pyrophosphatase/phosphodiesterase family. *Biochim. Biophys. Acta* 1638, 1–19.
  7. Goldfine, I.D., Maddux, B.A., Youngren, J.F., Reaven, G., Accili, D., Trischitta, V., Vigneri, R., and Frittitta, L. (2008). The role of membrane glycoprotein plasma cell antigen 1/ectonucleotide pyrophosphatase phosphodiesterase 1 in the pathogenesis of insulin resistance and related abnormalities. *Endocr. Rev.* 29, 62–75.
  8. Rutsch, F., Ruf, N., Vaingankar, S., Toliat, M.R., Suk, A., Hohne, W., Schauer, G., Lehmann, M., Roscioli, T., Schnabel, D., et al. (2003). Mutations in ENPP1 are associated with 'idiopathic' infantile arterial calcification. *Nat. Genet.* 34, 379–381.
  9. Rutsch, F., Böyer, P., Nitschke, Y., Ruf, N., Lorenz-Depiereux, B., Wittkamp, T., Weissen-Plenz, G., Fischer, R.J., Mughal, Z., Gregory, J.W., et al. (2008). Hypophosphatemia, hyperphosphaturia, and bisphosphonate treatment are associated with survival beyond infancy in generalized arterial calcification of infancy. *Circ. Cardiovasc. Genet.* 1, 133–140.
  10. Dlamini, N., Splitt, M., Durkan, A., Siddiqui, A., Padayachee, S., Hobbins, S., Rutsch, F., and Wraige, E. (2009). Generalized arterial calcification of infancy: phenotypic spectrum among three siblings including one case without obvious arterial calcifications. *Am. J. Med. Genet. A.* 149A, 456–460.
  11. Hessle, L., Johnson, K.A., Anderson, H.C., Narisawa, S., Sali, A., Goding, J.W., Terkeltaub, R., and Millan, J.L. (2002). Tissue-nonspecific alkaline phosphatase and plasma cell membrane glycoprotein-1 are central antagonistic regulators of bone mineralization. *Proc. Natl. Acad. Sci. USA* 99, 9445–9449.
  12. Okawa, A., Nakamura, I., Goto, S., Moriya, H., Nakamura, Y., and Ikegawa, S. (1998). Mutation in Npps in a mouse model of ossification of the posterior longitudinal ligament of the spine. *Nat. Genet.* 19, 271–273.
  13. Pendleton, A., Johnson, M.D., Hughes, A., Gurley, K.A., Ho, A.M., Doherty, M., Dixey, J., Gillet, P., Loeuille, D., McGrath, R., et al. (2002). Mutations in ANKH cause chondrocalcinosis. *Am. J. Hum. Genet.* 71, 933–940.
  14. Yamazaki, Y., Okazaki, R., Shibata, M., Hasegawa, Y., Satoh, K., Tajima, T., Takeuchi, Y., Fujita, T., Nakahara, K., Yamashita, T., et al. (2002). Increased circulatory level of biologically active full-length FGF-23 in patients with hypophosphatemic rickets/osteomalacia. *J. Clin. Endocrinol. Metab.* 87, 4957–4960.
  15. Imel, E.A., Peacock, M., Pitukcheewanont, P., Heller, H.J., Ward, L.M., Shulman, D., Kassem, M., Rackoff, P., Zimering, M., Dalkin, A., et al. (2006). Sensitivity of fibroblast growth factor 23 measurements in tumor-induced osteomalacia. *J. Clin. Endocrinol. Metab.* 91, 2055–2061.
  16. Lorenz-Depiereux, B., Benet-Pages, A., Eckstein, G., Tenenbaum-Rakover, Y., Wagenstaller, J., Tiosano, D., Gershoni-Baruch, R., Albers, N., Lichtner, P., Schnabel, D., et al. (2006). Hereditary hypophosphatemic rickets with hypercalciuria is caused by mutations in the sodium-phosphate cotransporter gene SLC34A3. *Am. J. Hum. Genet.* 78, 193–201.